

WECO

HYDRA Series

Reverse Osmosis
Drinking Water Filter
System Manual



Water Engineering Corporation
Long Beach, CA U.S.A
1 (888) 675-5187
sales@wecofilters.com



www.wecofilters.com

Inspect the System before Installation:

Please inspect the System and all connection fittings carefully, and make sure there is no damage during shipping. If you find a damaged or broken part, please DO NOT proceed with the installation, and contact us for a replacement, broken part or assistance via 1 (888) 675-5187

General Installation and Maintenance Requirements:

- Please make sure that the installation complies with State and local laws and regulations.
- Do not use with the water that is microbiologically unsafe or of unknown quality without adequate disinfection before or after system.
- System must be installed indoor.
- It is recommended that installation of the water filter be done by a professional plumber.



HYDRA-SET-3

Important !

It is recommended to change the 3 pre-filters at least every 6-8 months. It is advised to change them on time to avoid any damages to the RO System. It is advised to use WECO replacement filters. Using 'non-WECO' and poor quality filters may clog the RO system and will also damage the membrane.

Visit us on www.wecofilters.com or call us at 1 (888) 675-5187

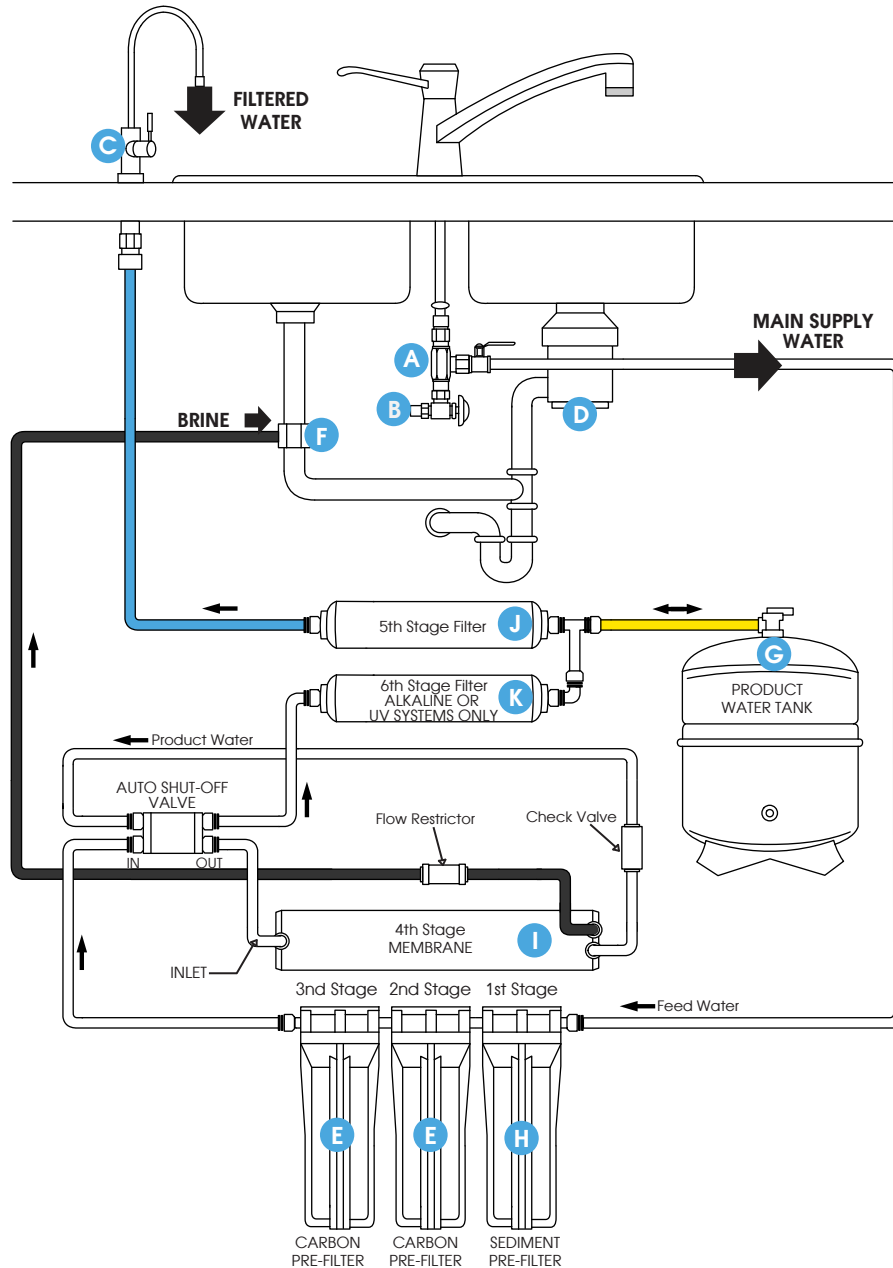

Fig. #1

- A** Water supply adapter valve
- B** Cold water shut-off valve
- C** Auxiliary faucet
- D** Garbage disposal
- E** Carbon Filters
- F** Drain Saddle
- G** Storage tank with valve in open Position
- H** Sediment Filter
- I** Membrane
- J** Inline GAC Filter
- K** Alkaline/UV Filter (optional)

Reverse Osmosis System Tubing Diagram

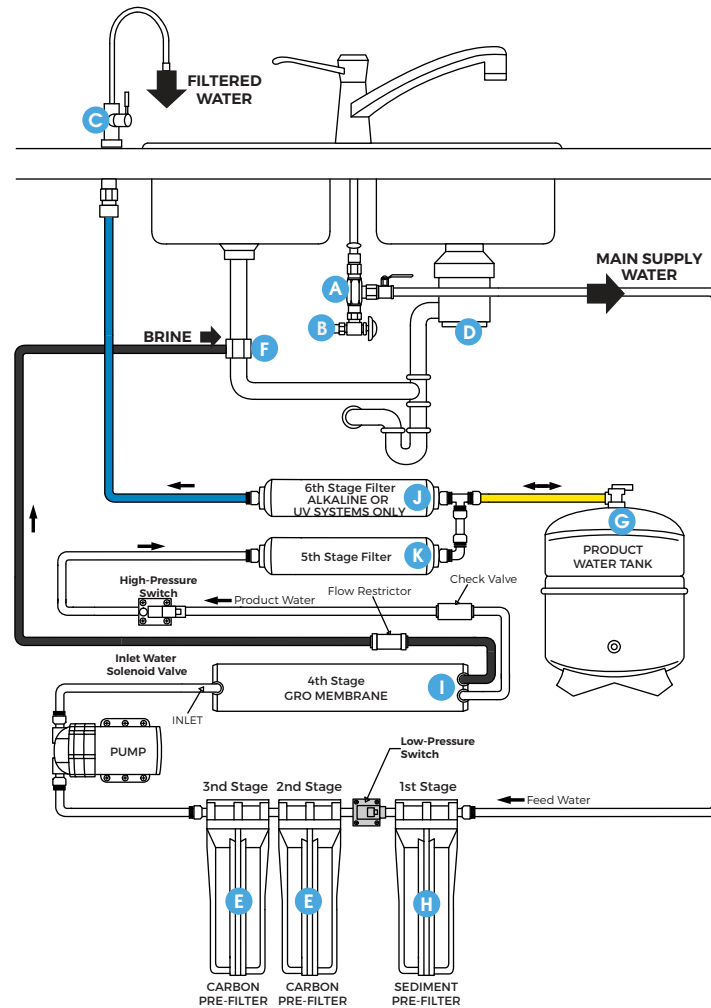

Fig. #2

- A** Water supply adapter valve
 - B** Cold water shut-off valve
 - C** Auxiliary faucet
 - D** Garbage disposal
 - E** Carbon Filters
 - F** Drain Saddle
- G** Storage tank with valve in open Position
 - H** Sediment Filter
 - I** Membrane
 - J** Inline GAC Filter
 - K** Alkaline/UV Filter (optional)

Reverse Osmosis System Electric Booster Pump Tubing Diagram

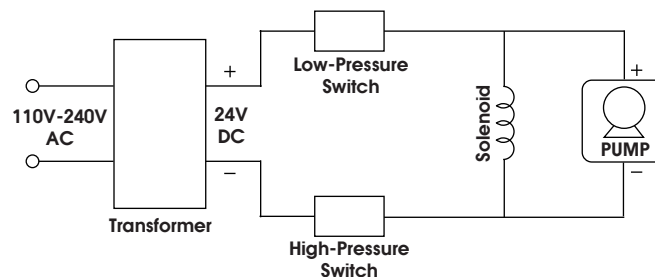

Fig. #3

Electrical Diagram

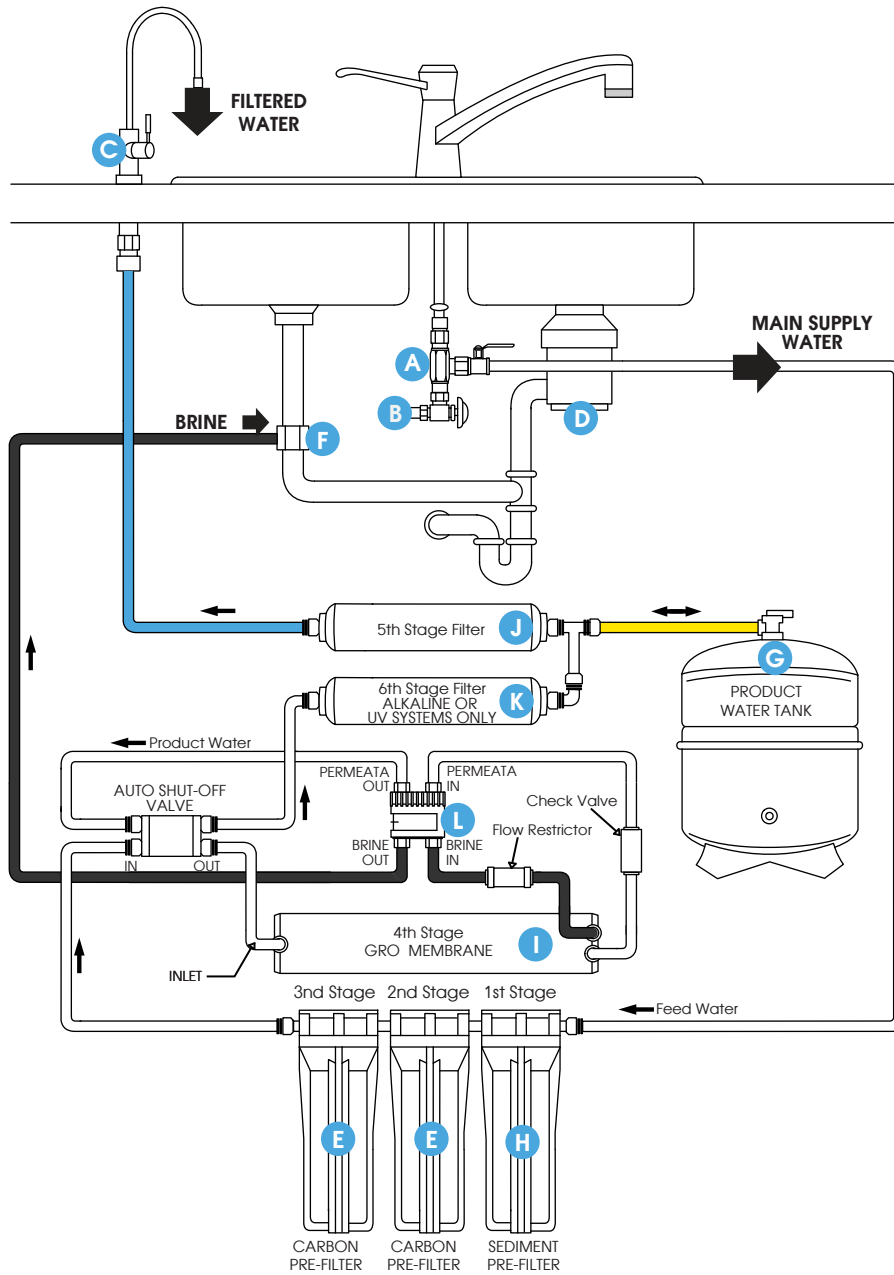

Fig. #4

- A** Water supply adapter valve
- B** Cold water shut-off valve
- C** Auxiliary faucet
- D** Garbage disposal
- E** Carbon Filters
- F** Drain Saddle
- G** Storage tank with valve in open Position
- H** Sediment Filter
- I** Membrane
- J** Inline GAC Filter
- K** Alkaline/UV Filter (optional)
- L** Permeate Pump

Reverse Osmosis System Electric Diagram with Permeate Pump

INSTALLATION INSTRUCTIONS

Tapping into the cold water line

(Using the water supply adapter model FW 1)

NOTE: The drinking water system must be connected to the COLD water supply only.

1. Turn off the cold water supply to the sink faucet by locating the Round or oblong handle on the right side of the sink cabinet and Turning clockwise until the water supply is off.

NOTE: If the cold water shut-off valve fails to turn off the water, the house water supply can be turned off at the main water supply.

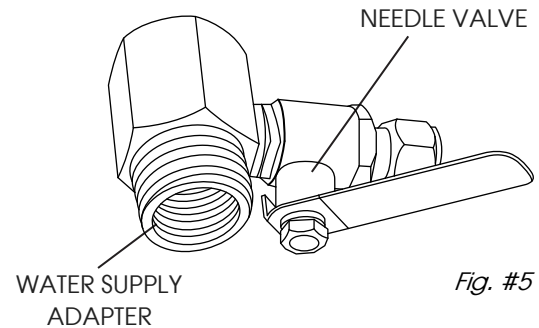

Fig. #5

2. The water supply adapter can be installed at the faucet Connection (A of Fig. #5) of the cold water line or at the shut-off Valve connection (B of Fig. #5).
3. Disconnect the threaded nut at the connection and thread the water supply adapter, with the flat washer in place, onto the connection and tighten. Connect the white tubing to the water supply adapter with the treaded nut and tighten.
4. Thread the needle valve into the adapter tightly and turn the handle clockwise all the way in. Turn on cold water supply to the sink faucet and check for leaks.

Drilling the hole for the faucet

NOTE: Safety glasses should be worn to protect your eyes while drilling the faucet hole.

1. For best results, a ½" carbide-tipped drill bit should be used to drill a hole into your sink for the auxiliary faucet.
2. Carefully select the faucet location making sure it will have a neat water fall pattern and that the faucet stud will be accessible from below once the hole is completed.
3. For Porcelain Sink: Before starting the drill motor, apply firm downward pressure on the bit until a crunching occurs. This will help keep the drill bit from moving.
4. For Stainless Steel Sink: Before using a ½" carbide drill bit, an indent should be made with a center punch to keep the drill bit from moving. A small pilot hole will also aid the ½" drill bit.
5. For best results, keep steady firm pressure during the start of the hole will cause excess wear on the bit and progress will be slow.
6. Once the hole is complete, clean the area of metal chips and roughness around the hole. Metal chips will stain Porcelain.

Mounting the faucet

Your unit comes complete with a long reach faucet.

NOTE: Air gap option installation instructions are available upon request. The following instructions is for non-air gap option.

1. Slide chrome cover plate and rubber gasket onto stem of faucet and place faucet onto sink with the stem going through the hole.
2. Place metal washer and lock washer over threaded stem of faucet and tighten nut from under the counter surface to lock the faucet into place. **DO NOT OVER TIGHTEN.**
3. Connect the blue tube to the faucet stem under the counter and tighten.

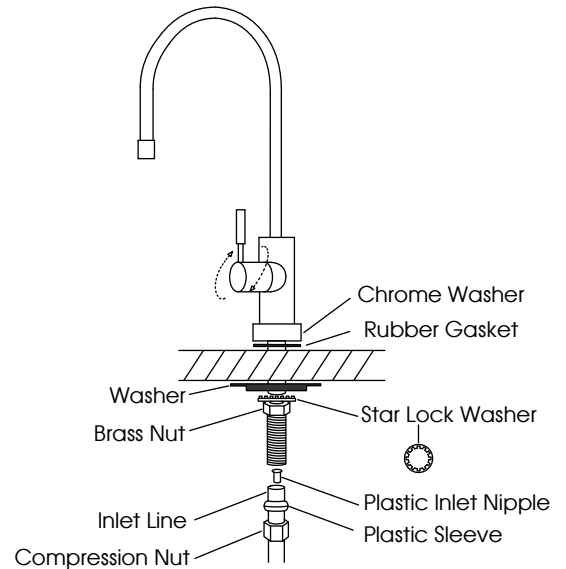

Fig. #6

Drain clamp installation

1. The drain clamp assembly should be installed above the trap and on the vertical or horizontal tailpiece (Fig. #7)

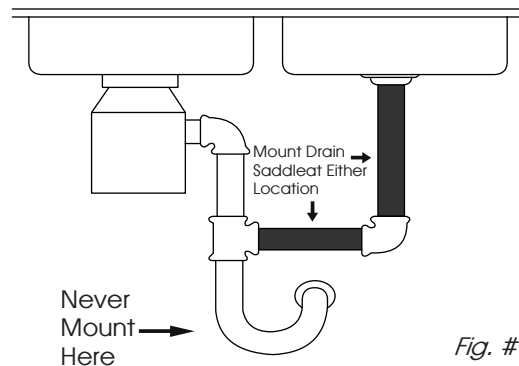

Fig. #7

2. Mark the hole position on the pipe and drill a $\frac{1}{4}$ " hole through one side of the pipe (Fig. #8).

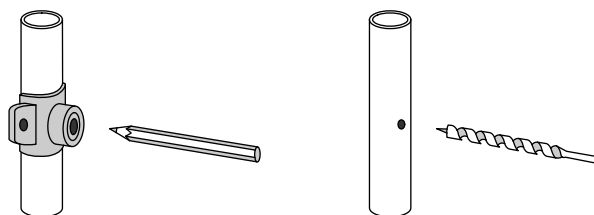

Fig. #8

3. Make sure to align drain saddle to drilled hole. Attach drain clamp to drain pipe and tighten the two screws evenly. (Fig. # 9)

NOTE: The center hole on the sponge must be removed.

4. Connect the Black tubing to the drain clamp.

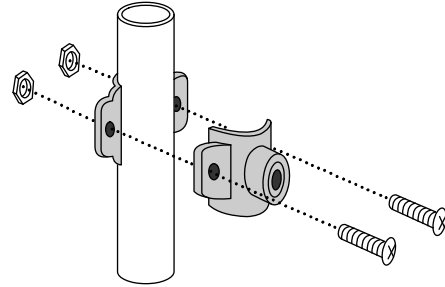

Fig. #9

Positioning the system

1. The head assembly will stand up in the sink cabinet or can be hung on screws provided.
2. The storage tank may be laid on its side.
3. The head assembly and/or storage tank maybe placed up to 15 feet from the point of use with nominal pressure loss.

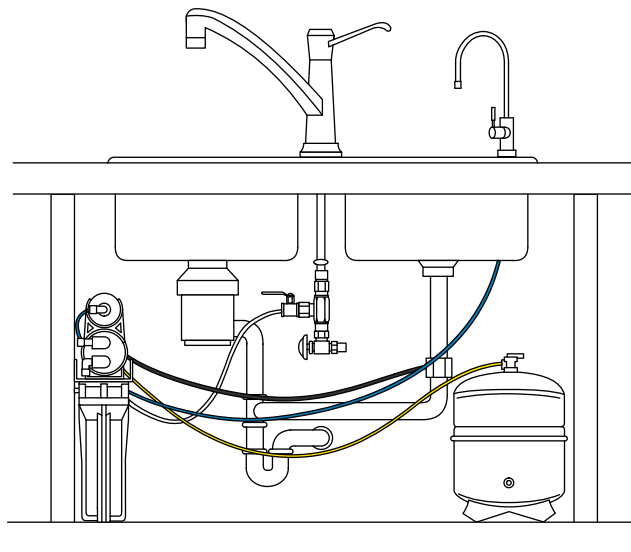

Fig. #10

CONNECTING THE SYSTEM

Use the color coded tubing to make the following connections:

- The **white** tubing connects the water supply adapter to the inlet side.
- The **blue** tubing connects the faucet to the outlet side.
- The **Black** tubing connects to the drain clamps.
- The **yellow** tubing connects the storage tank to the inlet side of the post carbon.

START-UP PROCEDURE

1. Check to see all connections are made
2. Check that the pre-filter and pre-carbon sumps are secure using the housing wrench provided.
3. Slowly turn on the water by turning the needle valve counterclockwise.
4. The valve handle on top of the tank should be in the open position, parallel to the valve body
5. The handle of the faucet should be perpendicular to the spigot (closed).
6. Check for leaks.
7. The RO/NF drinking water system makes 2 gallons of drinking water per hour and requires 1 to 2 hours before water is readily available.
8. During this initial fill period, you will hear water being discharged through the black drain line. This is normal as the contaminated water is being rejected by the reverse osmosis membrane.

**DO NOT DRINK THE WATER FROM THE FIRST TANK PRODUCED BY THE SYSTEM.
DISCHARGE THE WATER FROM THE STORAGE TANK BY OPENING THE FAUCET.
DISCHARGING MIGHT TAKE UP TO 15 MINUTES.**

If you have any difficulties with the installation, or require additional information on your unit, please consult with our factory technicians.

We thank you for purchasing our Reverse Osmosis / Nanofiltration unit for your high quality processed drinking water. In order to maintain this high quality water, it is important that scheduled maintenance be followed.

RECOMMENDED SYSTEM MAINTENANCE

To properly maintain your WECO drinking water system, please use
only genuine WECO water replacement filters at

www.wecofilters.com or call us at 1 (888) 675-5187



Sediment Pre-filter: The pre-filter protects the system and should be maintained regularly, a clear housing has been provided for your convenience. The show-white pre-Filter should be changed when the outside discolors to a cardboard brown color and before the inner surface discolors. The life of the pre- filter will depend upon the condition of your water supply and should be checked at 3-month intervals until a filter life is established (**average life 6 months**).



Carbon Block: Designed to remove chlorine form the water supply, as well as organic and inorganic substance before entering the TFC membrane (**average life 12 months**).

Post-Carbon: The post-filter should be changed when you experience an unusual taste and/or odor to the water and has a nominal life of **1 year**.

Membrane: The high quality Thin Film Composite membrane should last between **2 to 4 years** depending on the quality of your local water.



Drain your storage tank twice each month to extend the membrane and have the freshest water in the storage tank. Drain the storage tank by lifting the faucet handle into the parallel position with the spigot until water flow stops from the tank. Return the faucet handle to the closed position and the tank will refill in 2 hours. It is best to drain the system before retiring for the evening.

Reverse Osmosis Systems Replacement Cartridges

System	Stage 1 Filter	Stage 2 Filter	Stage 3 Filter	Stage 4 Filter	Stage 5 Filter	Stage 6 Filter	Stage 7 Filter
HYDRA-50	SDC-25-1005	CB-25-1005	SMCB-2510	TW-1812-50	ICF-10Q	-	-
HYDRA-75	SDC-25-1005	CB-25-1005	SMCB-2510	TW-1812-75	ICF-10Q	-	-
HYDRA-75PMP	SDC-25-1005	CB-25-1005	SMCB-2510	TW-1812-75	ICF-10Q	-	-
HYDRA-75PERM	SDC-25-1005	CB-25-1005	SMCB-2510	TW-1812-75	ICF-10Q	-	-
HYDRA-75UV	SDC-25-1005	CB-25-1005	SMCB-2510	TW-1812-75	ICF-10Q	GL10SE4P	-
HYDRA-75UVPMP	SDC-25-1005	CB-25-1005	SMCB-2510	TW-1812-75	ICF-10Q	GL10SE4P	-
HYDRA-75ALK	SDC-25-1005	CB-25-1005	SMCB-2510	TW-1812-75	ICF-10Q	ICF-2512	-
HYDRA-75ALKPMP	SDC-25-1005	CB-25-1005	SMCB-2510	TW-1812-75	ICF-10Q	ICF-2512	-
HYDRA-75UVALKPMP	SDC-25-1005	CB-25-1005	SMCB-2510	TW-1812-75	ICF-10Q	ICF-2512	GL10SE4P

CHANGING THE PRE-FILTERS

1. Turn OFF cold water supply to RO system. Turn OFF tank's ball-valve. Lift up RO faucet lever briefly to relief the built-up pressure inside the RO system. This will make opening the housings easier.
2. Open housing: Have the RO standing upright. Slip the plastic wrench onto the #1 housing. Looking down from a top view, you should open the housing turning clockwise. If necessary, lay RO down on the floor to get a better leverage. If the housing is too tight, use a hammer and tap on the wrench handle to help turn the wrench.
3. Discard 3 used filters, wash housings with mild soap, rinse off. Put 3 new filters into their respective housings: sediment filter in stage-1, carbon block filters in stages 2 & 3.
4. Close up the housings. Make sure each housing has a black O-ring in the thread groves. Use wrench to tighten each housing.
5. Remember: Turn ON the cold water supply and OPEN the tank valve after finished changing filters!
6. **Check for leaks!**

CHANGING THE MEMBRANE

CAUTION: ANY REPLACEMENT FILTERS OR MEMBRANE NOT RECOMMENDED BY THE FACTORY CAN CAUSE SEVERE DAMAGE TO THE SYSTEM AND VOIDS ALL WARRANTIES.

1. Shut off the feed water to the system by turning the saddle valve on the water supply adapter clockwise until it stops.
2. Close the storage tank ball valve by turning the handle perpendicular to the valve body.
3. Open the drinking water faucet relive pressure.
4. Allow 3-5 minutes for pressure in the system to drop.
5. Disconnect the tubing from the membrane cap by pushing in and holding down the end collar ring surrounding the quick connect elbow fitting while gently pulling back on the tubing.
6. Remove the membrane housing cap by turning counter-clockwise.
7. Using a pair of needle nose pliers, remove and discard the used membrane.
8. Rinse the inside of membrane housing with warm water.
9. Using pliers, insert the new membrane all the way into the housing (double o-ring end first), making sure it is properly seated.
10. Replace and hand-tighten the membrane housing cap by turning clockwise.
11. Reconnect the removed tubing by pushing it into the elbow fitting in the housing cap.
12. Gently pull back on the tubing to insure a leak free connection.

OPERATING LIMITS

	Max. TDS	Water Temperature	pH Range	Water Pressure
Standard RO System	2000 ppm	40 - 85 °F	2 - 11	45 - 85 PSI
RO with Booster Pump	2000 ppm	40 - 85 °F	2 - 11	45 - 85 PSI

MEMBRANE PERFORMANCE

HYDRON Membrane Technology Membrane Elements

HYDRON Membrane Elements are a reliable alternative for your resi-dential and small system membrane needs. HYDRON Membranes are manufactured in a State-of-the-Art, ISO-9001-2000 certified automatic rolling facility, providing you with a precise and advanced membrane element that not only delivers an attractive cost to benefit ratio, but also gives you a membrane that has consistently of high quality and performance.

HYDRON Membrane Elements can be used in a variety of small size system applications, such as household water purification, laboratory, hydroponics, hospital, and many other applications where a reliable, performance membrane is needed.



TW Membrane Specifications

Model	Part Number	Applied Pressure PSIG (BAR)	Average Permeated Flow GPD (m3/d)	Stable Rejection Rate (%)	Minimum Rejection Rate (%)
1.8"	TW-1812-50	60 (4.1)	50 (0.19)	97.5	96.0
	TW-1812-75	60 (4.1)	75 (0.28)	97.5	96.0

Membrane Type

Polyamide Composite

Testing Conditions

Testing Pressure	60 psi	(0.41Mpa) (4.1 BAR)
Temperature of Testing Solution	75°F	(25°C)
Concentration of Testing Solution (NaCl)	250ppm	
pH Value of Testing Solution	7.5	
Recovery Rate of Single Membrane Element	15%	

Extreme Operating Conditions

Max. Working Pressure	300psi	(2.07Mpa) (20.7 BAR)
Max. Feedwater Temperature	113 °F	(45°C)
Max. Feedwater SDI	5	
Free Chlorine Concentration of Feedwater	<0.1 ppm	
pH Range of Feedwater during Continuous Operation	3-10	
pH Range of Feedwater during Chemical Cleaning	2-12	
Max. Pressure Drop of Single Membrane Element	10 psi	(0.07 Mpa) (0.7 BAR)
Max. Temperature for Continuous Operation above pH 10	95°F	(35°C)

Important Information

Under certain conditions, the presence of free chlorine and other oxidizing agents will cause premature membrane failure. Since oxidation damage is not covered under warranty, HYDRON recommends removing residual free chlorine by pre treatment prior to membrane exposure. Any specific application must be limited within the extreme operating conditions. We strongly recommend you to refer to the latest edition of technology manual and design guide prepared by HYDRON Membrane Technology or consult experts proficient in membrane technology. In case the customer fails to follow the operating conditions as specified in this manual, HYDRON Membrane Technology will assume no liability for all results.

The permeate flow listed in the table is the average value. The permeate flow of single membrane element is within a tolerance not exceeding $\pm 20\%$ of nominal value.

Discard the RO-filtered water produced during the first one hour after system start-up.

During storage time and run time, it is strictly prohibited to dose any chemical medicament that may be harmful.

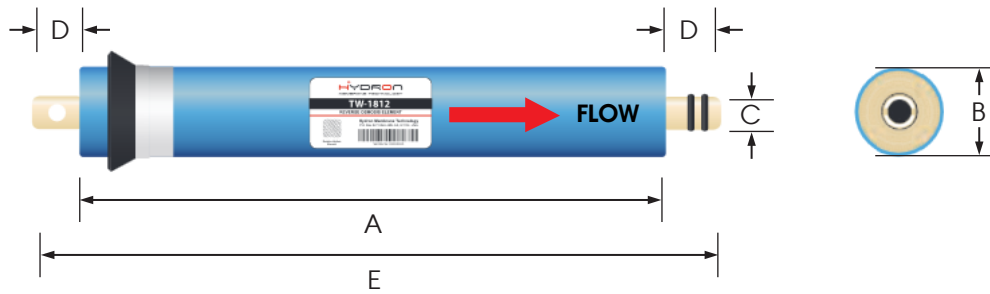
**TW-1812**

A = 10.06" (255.5 mm) **D** = 0.8125" (20.63 mm)
B = 1.796" (45.61 mm) **E** = 11.68" (296.7 mm)
C = 0.687" (17.46 mm)



This Membrane is Tested and Certified by NSF International against NSF / ANSI Standard 58 for material requirements only.

COMPONENT

**CUSTOMER SATISFACTION IS OF PRIMARY CONCERN,
PLEASE CALL IN THE EVENT THERE IS A SERVICE PROBLEM.**

Notice: Your RO system has been thoroughly tested and inspected for production, rejection, leaks and shut-off functions at our factory. Therefore, it might have some water in it.

Warning: Do not use this system if feed water has biological contamination or of unknown source. For operating parameters, please contact our technical support department.

CONTACT US

For replacements cartridges and accessories shop

www.wecofilters.com

For questions and concerns, please feel free to
contact our support staff.

Phone: 1 (888) 675-5187

Email: sales@wecofilters.com

Water Engineering Corporation

1037 Stanley Ave, Long Beach,
CA 90804, USA

This page is intentionally left blank

WECO HYDRA Series
Reverse Osmosis
Drinking Water Filter
System Manual

WECO

www.wecofilters.com



Water Engineering Corporation

Long Beach, CA U.S.A

1 (888) 675-5187

sales@wecofilters.com